



***msi***<sup>™</sup>

# **A75MA-G55 series**

MS-7696 (v1.x) Mainboard

G52-76961X2

## Copyright Notice

The material in this document is the intellectual property of **MICRO-STAR INTERNATIONAL**. We take every care in the preparation of this document, but no guarantee is given as to the correctness of its contents. Our products are under continual improvement and we reserve the right to make changes without notice.

## Trademarks

All trademarks in this manual are properties of their respective owners.

- MSI® is registered trademark of Micro-Star Int'l Co.,Ltd.
- NVIDIA® is registered trademark of NVIDIA Corporation.
- ATI® is registered trademark of AMD Corporation.
- AMD® is registered trademarks of AMD Corporation.
- Intel® is registered trademarks of Intel Corporation.
- Windows® is registered trademarks of Microsoft Corporation.
- AMI® is registered trademark of American Megatrends Inc.
- Award® is a registered trademark of Phoenix Technologies Ltd.
- Sound Blaster® is registered trademark of Creative Technology Ltd.
- Realtek® is registered trademark of Realtek Semiconductor Corporation.
- JMicon® is registered trademark of JMicon Technology Corporation.
- Netware® is a registered trademark of Novell, Inc.
- Lucid® is trademarks of LucidLogix Technologies, Ltd.
- VIA® is registered trademark of VIA Technologies, Inc.
- ASMedia® is registered trademark of ASMedia Technology Inc.
- iPad, iPhone, and iPod are trademarks of Apple Inc.

## Revision History

Revision	Revision History	Date
V1.0	First release for PCB 1.X	2011/ 05
V1.1	Update for PCB 1.X	2011/ 06

## Technical Support

If a problem arises with your system and no solution can be obtained from the user's manual, please contact your place of purchase or local distributor. Alternatively, please try the following help resources for further guidance.

- ☐ Visit the MSI website for technical guide, BIOS updates, driver updates, and other information: <http://www.msi.com/service/download>
- ☐ Contact our technical staff at: <http://support.msi.com>

## Safety Instructions

- Always read the safety instructions carefully.
- Keep this User's Manual for future reference.
- Keep this equipment away from humidity.
- Lay this equipment on a reliable flat surface before setting it up.
- The openings on the enclosure are for air convection hence protects the equipment from overheating. **DO NOT COVER THE OPENINGS.**
- Make sure the voltage of the power source is at 110/220V before connecting the equipment to the power inlet.
- Place the power cord such a way that people can not step on it. Do not place anything over the power cord.
- Always Unplug the Power Cord before inserting any add-on card or module.
- All cautions and warnings on the equipment should be noted.
- Never pour any liquid into the opening that can cause damage or cause electrical shock.
- If any of the following situations arises, get the equipment checked by service personnel:
  - The power cord or plug is damaged.
  - Liquid has penetrated into the equipment.
  - The equipment has been exposed to moisture.
  - The equipment does not work well or you can not get it work according to User's Manual.
  - The equipment has been dropped and damaged.
  - The equipment has obvious sign of breakage.

**DO NOT LEAVE THIS EQUIPMENT IN AN ENVIRONMENT ABOVE 60°C (140°F), IT MAY DAMAGE THE EQUIPMENT..**

**CAUTION:** There is a risk of explosion, if battery is incorrectly replaced.

Replace only with the same or equivalent type recommended by the manufacturer.

**警告使用者:**

這是甲類資訊產品，在居住的環境中使用時，可能會造成無線電干擾，在這種情況下，使用者會被要求採取某些適當的對策。



**廢電池請回收**

For better environmental protection, waste batteries should be collected separately for recycling special disposal.

## FCC-B Radio Frequency Interference Statement

This equipment has been tested and found to comply with the limits for a Class B digital device, pursuant to Part 15 of the FCC Rules. These limits are designed to provide reasonable protection against harmful interference in a residential installation. This equipment generates, uses and can radiate radio frequency energy and, if not installed and used in accordance with the instructions, may cause harmful interference to radio communications. However, there is no guarantee that interference will not occur in a particular installation. If this equipment does cause harmful interference to radio or television reception, which can be determined by turning the equipment off and on, the user is encouraged to try to correct the interference by one or more of the measures listed below.



- Reorient or relocate the receiving antenna.
- Increase the separation between the equipment and receiver.
- Connect the equipment into an outlet on a circuit different from that to which the receiver is connected.
- Consult the dealer or an experienced radio/television technician for help.

### Notice 1

The changes or modifications not expressly approved by the party responsible for compliance could void the user's authority to operate the equipment.

### Notice 2

Shielded interface cables and A.C. power cord, if any, must be used in order to comply with the emission limits.

VOIR LA NOTICE D'INSTALLATION AVANT DE RACCORDER AU RESEAU.

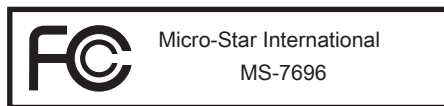

This device complies with Part 15 of the FCC Rules. Operation is subject to the following two conditions:

- 1) this device may not cause harmful interference, and
- 2) this device must accept any interference received, including interference that may cause undesired operation.

## WEEE (Waste Electrical and Electronic Equipment) Statement

### ENGLISH

To protect the global environment and as an environmentalist, MSI must remind you that...



Under the European Union ("EU") Directive on Waste Electrical and Electronic Equipment, Directive 2002/96/EC, which takes effect on August 13, 2005, products of "electrical and electronic equipment" cannot be discarded as municipal wastes anymore, and manufacturers of covered electronic equipment will be obligated to take back such products at the end of their useful life. MSI will comply with the product take back requirements at the end of life of MSI-branded products that are sold into the EU. You can return these products to local collection points.

### DEUTSCH

Hinweis von MSI zur Erhaltung und Schutz unserer Umwelt

Gemäß der Richtlinie 2002/96/EG über Elektro- und Elektronik-Altgeräte dürfen Elektro- und Elektronik-Altgeräte nicht mehr als kommunale Abfälle entsorgt werden. MSI hat europaweit verschiedene Sammel- und Recyclingunternehmen beauftragt, die in die Europäische Union in Verkehr gebrachten Produkte, am Ende seines Lebenszyklus zurückzunehmen. Bitte entsorgen Sie dieses Produkt zum gegebenen Zeitpunkt ausschliesslich an einer lokalen Altgerätesammelstelle in Ihrer Nähe.

### FRANÇAIS

En tant qu'écologiste et afin de protéger l'environnement, MSI tient à rappeler ceci...

Au sujet de la directive européenne (EU) relative aux déchets des équipement électriques et électroniques, directive 2002/96/EC, prenant effet le 13 août 2005, que les produits électriques et électroniques ne peuvent être déposés dans les décharges ou tout simplement mis à la poubelle. Les fabricants de ces équipements seront obligés de récupérer certains produits en fin de vie. MSI prendra en compte cette exigence relative au retour des produits en fin de vie au sein de la communauté européenne. Par conséquent vous pouvez retourner localement ces matériels dans les points de collecte.

### РУССКИЙ

Компания MSI предпринимает активные действия по защите окружающей среды, поэтому напоминаем вам, что....

В соответствии с директивой Европейского Союза (ЕС) по предотвращению загрязнения окружающей среды использованным электрическим и электронным оборудованием (директива WEEE 2002/96/EC), вступающей в силу 13 августа 2005 года, изделия, относящиеся к электрическому и электронному оборудованию, не могут рассматриваться как бытовой мусор, поэтому производители вышеперечисленного электронного оборудования обязаны принимать его для переработки по окончании срока службы. MSI обязуется соблюдать требования по приему продукции, проданной под маркой MSI на территории ЕС, в переработку по окончании срока службы. Вы можете вернуть эти изделия в специализированные пункты приема.

## ESPAÑOL

MSI como empresa comprometida con la protección del medio ambiente, recomienda: Bajo la directiva 2002/96/EC de la Unión Europea en materia de desechos y/o equipos electrónicos, con fecha de rígor desde el 13 de agosto de 2005, los productos clasificados como “eléctricos y equipos electrónicos” no pueden ser depositados en los contenedores habituales de su municipio, los fabricantes de equipos electrónicos, están obligados a hacerse cargo de dichos productos al termino de su período de vida. MSI estará comprometido con los términos de recogida de sus productos vendidos en la Unión Europea al final de su periodo de vida. Usted debe depositar estos productos en el punto limpio establecido por el ayuntamiento de su localidad o entregar a una empresa autorizada para la recogida de estos residuos.

## NEDERLANDS

Om het milieu te beschermen, wil MSI u eraan herinneren dat...

De richtlijn van de Europese Unie (EU) met betrekking tot Vervuiling van Electriche en Electronische producten (2002/96/EC), die op 13 Augustus 2005 in zal gaan kunnen niet meer beschouwd worden als vervuiling. Fabrikanten van dit soort producten worden verplicht om producten retour te nemen aan het eind van hun levenscyclus. MSI zal overeenkomstig de richtlijn handelen voor de producten die de merknaam MSI dragen en verkocht zijn in de EU. Deze goederen kunnen geretourneerd worden op lokale inzamelingspunten.

## SRPSKI

Da bi zaštitili prirodnu sredinu, i kao preduzeće koje vodi računa o okolini i prirodnoj sredini, MSI mora da vas pedesti da...

Po Direktivi Evropske unije (“EU”) o odbačenoj ekelektronskoj i električnoj opremi, Direktiva 2002/96/EC, koja stupa na snagu od 13. Avgusta 2005, proizvodi koji spadaju pod “elektronsku i električnu opremu” ne mogu više biti odbačeni kao običan otpad i proizvođači ove opreme biće prinuđeni da uzmu natrag ove proizvode na kraju njihovog uobičajenog veka trajanja. MSI će poštovati zahtev o preuzimanju ovakvih proizvoda kojima je istekao vek trajanja, koji imaju MSI oznaku i koji su prodati u EU. Ove proizvode možete vratiti na lokalnim mestima za prikupljanje.

## POLSKI

Aby chronić nasze środowisko naturalne oraz jako firma dbająca o ekologię, MSI przypomina, że...

Zgodnie z Dyrektywą Unii Europejskiej (“UE”) dotyczącą odpadów produktów elektrycznych i elektronicznych (Dyrektywa 2002/96/EC), która wchodzi w życie 13 sierpnia 2005, tzw. “produkty oraz wyposażenie elektryczne i elektroniczne” nie mogą być traktowane jako śmieci komunalne, tak więc producenci tych produktów będą zobowiązani do odbierania ich w momencie gdy produkt jest wycofywany z użycia. MSI wypełni wymagania UE, przyjmując produkty (sprzedawane na terenie Unii Europejskiej) wycofywane z użycia. Produkty MSI będzie można zwracać w wyznaczonych punktach zbiorczych.

## TÜRKÇE

Çevreci özelliğiyle bilinen MSI dünyada çevreyi korumak için hatırlatır:

Avrupa Birliği (AB) Kararnamesi Elektrik ve Elektronik Malzeme Atığı, 2002/96/EC Kararnamesi altında 13 Ağustos 2005 tarihinden itibaren geçerli olmak üzere, elektrikli ve elektronik malzemeler diğer atıklar gibi çöpe atılmayacak ve bu elektronik cihazların üreticileri, cihazların kullanım süreleri bittikten sonra ürünleri geri toplamakla yükümlü olacaktır. Avrupa Birliği'ne satılan MSI markalı ürünlerin kullanım süreleri bittiğinde MSI ürünlerin geri alınması isteği ile işbirliği içerisinde olacaktır. Ürünlerinizi yerel toplama noktalarına bırakabilirsiniz.

## ČESKY

Záleží nám na ochraně životního prostředí - společnost MSI upozorňuje...

Podle směrnice Evropské unie ("EU") o likvidaci elektrických a elektronických výrobků 2002/96/EC platné od 13. srpna 2005 je zakázáno likvidovat "elektrické a elektronické výrobky" v běžném komunálním odpadu a výrobci elektrických výrobků, na které se tato směrnice vztahuje, budou povinni odebírat takové výrobky zpět po skončení jejich životnosti. Společnost MSI splní požadavky na odebírání výrobků značky MSI, prodávaných v zemích EU, po skončení jejich životnosti. Tyto výrobky můžete odevzdat v místních sběrnách.

## MAGYAR

Annak érdekében, hogy környezetünket megvédjük, illetve környezetvédőként fellépve az MSI emlékezteti Önt, hogy ...

Az Európai Unió („EU”) 2005. augusztus 13-án hatályba lépő, az elektromos és elektronikus berendezések hulladékairól szóló 2002/96/EK irányelve szerint az elektromos és elektronikus berendezések többé nem kezelhetőek lakossági hulladékként, és az ilyen elektronikus berendezések gyártói köteleessé válnak az ilyen termékek visszavételére azok hasznos élettartama végén. Az MSI betartja a termékvisszavétellel kapcsolatos követelményeket az MSI márkánév alatt az EU-n belül értékesített termékek esetében, azok élettartamának végén. Az ilyen termékeket a legközelebbi gyűjtőhelyre viheti.

## ITALIANO

Per proteggere l'ambiente, MSI, da sempre amica della natura, ti ricorda che....

In base alla Direttiva dell'Unione Europea (EU) sullo Smaltimento dei Materiali Elettrici ed Elettronici, Direttiva 2002/96/EC in vigore dal 13 Agosto 2005, prodotti appartenenti alla categoria dei Materiali Elettrici ed Elettronici non possono più essere eliminati come rifiuti municipali: i produttori di detti materiali saranno obbligati a ritirare ogni prodotto alla fine del suo ciclo di vita. MSI si adegnerà a tale Direttiva ritirando tutti i prodotti marchiati MSI che sono stati venduti all'interno dell'Unione Europea alla fine del loro ciclo di vita. È possibile portare i prodotti nel più vicino punto di raccolta

# CONTENTS

Copyright Notice .....	ii
Trademarks .....	ii
Revision History.....	ii
Technical Support.....	ii
Safety Instructions.....	iii
FCC-B Radio Frequency Interference Statement.....	iv
WEEE (Waste Electrical and Electronic Equipment) Statement .....	v
<b>Chapter 1 Getting Started.....</b>	<b>1-1</b>
Mainboard Specifications .....	1-2
Mainboard Layout .....	1-4
Packing Contents .....	1-5
Optional Accessories .....	1-5
<b>Chapter 2 Hardware Setup.....</b>	<b>2-1</b>
Quick Components Guide .....	2-2
Mounting Screw Holes .....	2-3
CPU (Central Processing Unit) .....	2-4
Memory .....	2-7
Power Supply .....	2-9
Back Panel.....	2-10
Connectors.....	2-12
Jumper .....	2-18
Slots .....	2-19
<b>Chapter 3 BIOS Setup.....</b>	<b>3-1</b>
Entering Setup .....	3-2
The Menu Bar .....	3-4
Main Menu .....	3-5
Advanced .....	3-6
Overclocking .....	3-11
M-Flash .....	3-15
Security .....	3-16
Boot.....	3-18
Save & Exit.....	3-19



---

<b>Appendix A Realtek Audio</b> .....	<b>A-1</b>
Installing the Realtek HD Audio Driver.....	A-2
Software Configuration.....	A-3
Hardware Default Setting.....	A-5
<b>Appendix B AMD RAID</b> .....	<b>B-1</b>
RAID Configuration .....	B-2



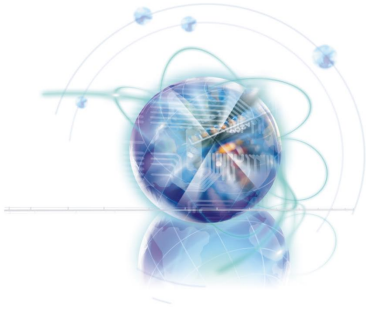

## Chapter 1

# Getting Started

Thank you for choosing the **A75MA-G55 Series** (MS-7696 v1.X) Micro-ATX mainboard. The **A75MA-G55 Series** mainboards are based on **AMD® Hudson D3** chipset for optimal system efficiency. Designed to fit the advanced **AMD® FM1** processors, the **A75MA-G55 Series** deliver a high performance and professional desktop platform solution.

## Mainboard Specifications

---

### Processor Support

- AMD® Llano APU in the FM1 package.  
(For the latest information about APU, please visit <http://www.msi.com/service/cpu-support>)

### Chipset

- AMD® Hudson D3

### Memory Support

- DDR3 1600/ 1333/ 1066 SDRAM (total 32 GB Max)
- 4 DDR3 DIMMs (240-pin/ 1.5V) support dual channel mode  
(For more information on compatible components, please visit <http://www.msi.com/service/test-report>)

### LAN

- Supports LAN 10/ 100/ 1000 Fast Ethernet by Realtek® RTL8111E

### Audio

- Chip integrated by Realtek® ALC887
- Flexible 8-channels audio-out
- Compliant with Azalia 1.0 Spec

### SATA

- 6 SATA 6Gb/s ports by AMD® Hudson D3

### RAID

- SATA1~6 supports RAID 0/ 1/ 10 mode by AMD® Hudson D3

### USB 3.0

- 2 USB 3.0 rear IO ports by AMD® Hudson D3
- 1 USB 3.0 onboard connector by AMD® Hudson D3

### Dual Graphics

- Supports AMD® Dual Graphics Technology with "Lynx" platform\*  
\*(Please note that you have to connect the monitor to an onboard graphics output for enabling the AMD® "Dual Graphics" technology.)  
\*(Please visit the AMD® official website to find the supported Dual Graphics combinations of APU and discrete GPU for achieving this technology.)  
\*(E2-series APU doesn't support Dual Graphics technology.)

### Multi-GPU

- Supports AMD® CrossFireX™ Technology

## Connectors

- Back panel
  - 1 PS/2 keyboard/ mouse combo port
  - 1 HDMI port\*\*
  - 1 VGA port
  - 1 DVI-D port\*\*
  - 4 USB 2.0 ports
  - 2 USB 3.0 ports
  - 1 LAN port
  - 6 flexible audio ports
- \*\* (This mainboard doesn't support HDMI-output & DVI-D-output simultaneously.)
- On-Board
  - 2 USB 2.0 connectors
  - 1 USB 3.0 connector
  - 1 S/PDIF-out connector
  - 1 Front Panel Audio connector
  - 1 Chassis Intrusion connector
  - 1 TPM Module connector
  - 1 Serial Port connector
  - 1 Parallel Port connector

## Slots

- 2 PCIe x16 slots (PCI\_E1 supports up to PCIe x16 speed, PCI\_E2 supports up to PCIe x4 speed)
- 1 PCIe x1 slot
- 1 PCI slot, support 3.3V/ 5V PCI bus Interface

## Form Factor

- Micro-ATX (24.4 cm X 24.4 cm)

## Mounting screw holes

- 8 mounting screw holes

# Mainboard Layout

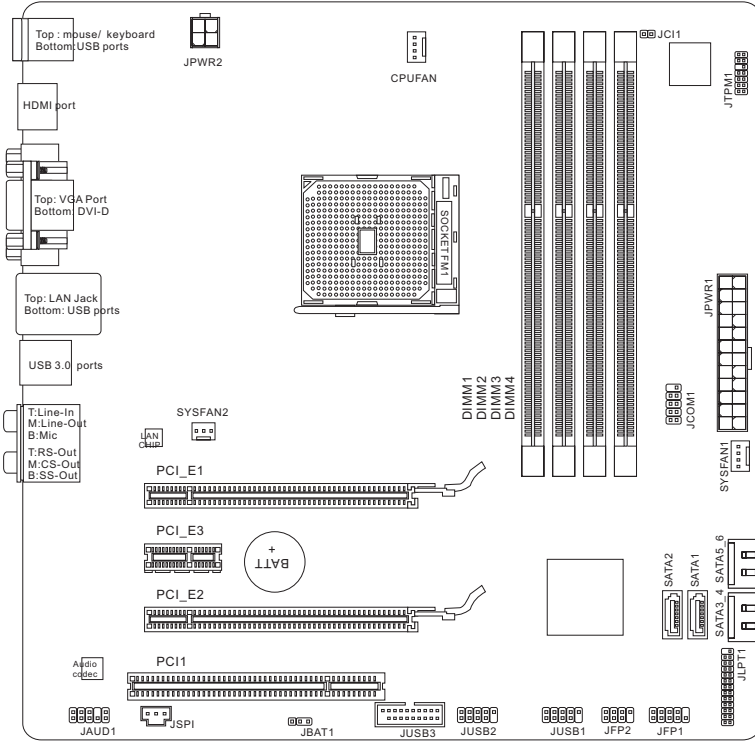

**A75MA-G55 Series (MS-7696 v1.X) Micro-ATX Mainboard**

## Packing Contents

---



Mainboard

Driver / Utility  
DVD

User Guide

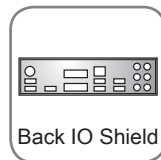

Back IO Shield



SATA Cable

## Optional Accessories

---



M-Connector

USB 3.0  
BracketSATA Power  
Cable

\* These pictures are for reference only and may vary without notice.

\* The packing contents may vary according to the model you purchased.

\* If you need to purchase the optional accessories, please visit <http://www.msi.com/index.php> to inquire the part numbers or consult the dealer.





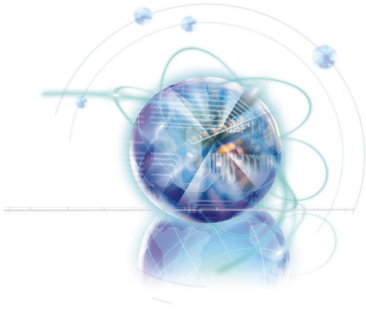

## Chapter 2

# Hardware Setup

This chapter provides you with the information about hardware setup procedures. While performing the installation, be careful in holding the components and following the installation procedures. For some components, if you install in the wrong orientation, the components will not work properly.

Use a grounded wrist strap before handling computer components. Static electricity may damage the components.

# Quick Components Guide

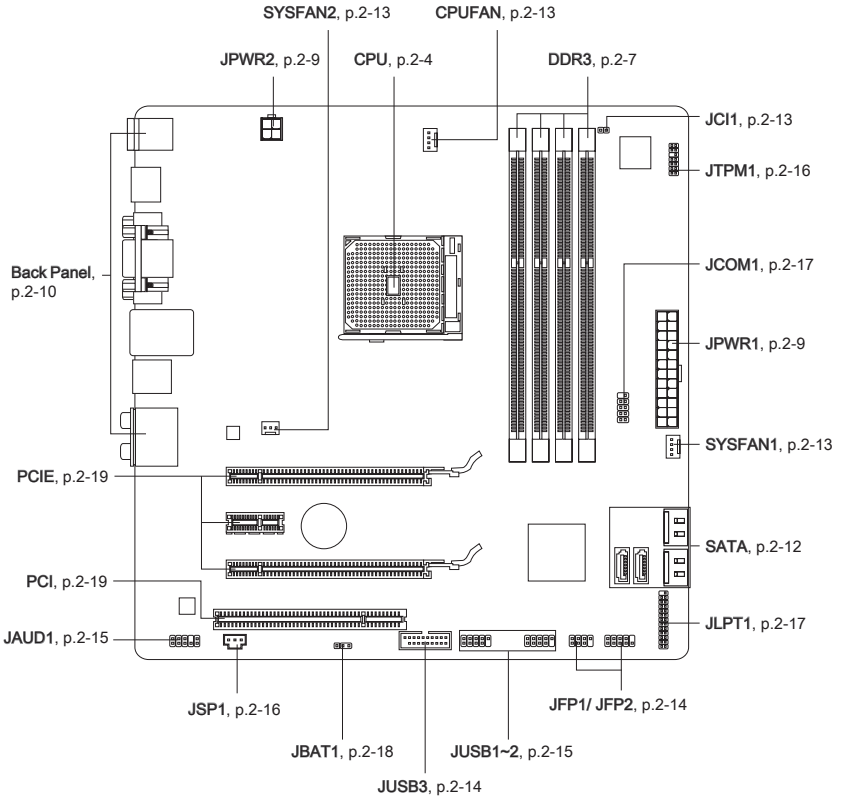

## Mounting Screw Holes

When you install the mainboard, you have to place the mainboard into the chassis in the correct direction. The locations of screws holes on the mainboard are shown as below.

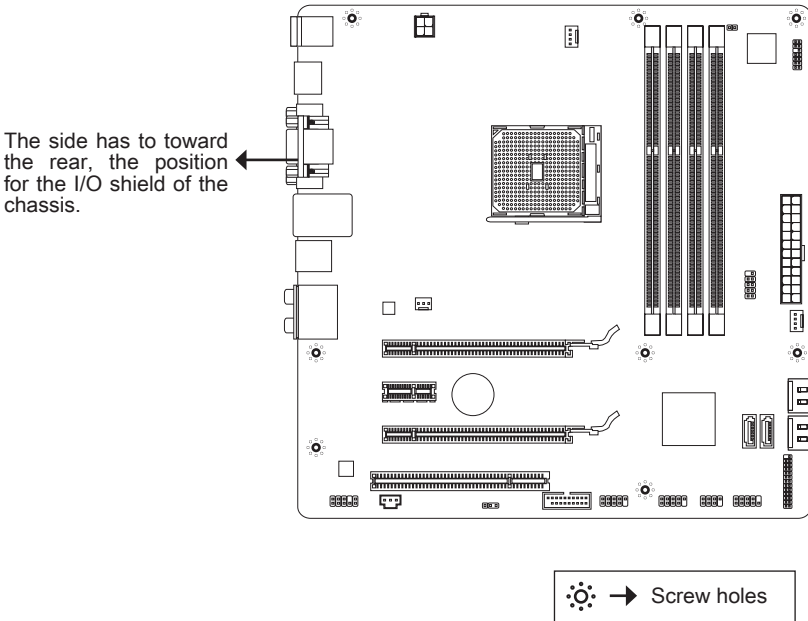

Refer above picture to install standoffs in the appropriate locations on chassis and then screw through the mainboard screw holes into the standoffs.

### **Important**

- *To prevent damage to the mainboard, any contact between the mainboard circuit and chassis or unnecessary standoffs mounted on the chassis is prohibited.*
- *Please make sure there are no metal components placed on the mainboard or within the chassis that may cause short circuit of the mainboard.*

## CPU (Central Processing Unit)

When you are installing the CPU, make sure to install the cooler to prevent overheating. If you do not have the CPU cooler, consult your dealer before turning on the computer. For the latest information about CPU, please visit <http://www.msi.com/service/cpu-support>

### **Important**

#### **Overheating**

*Overheating will seriously damage the CPU and system. Always make sure the cooling fan can work properly to protect the CPU from overheating. Make sure that you apply an even layer of thermal paste (or thermal tape) between the CPU and the heatsink to enhance heat dissipation.*

#### **Replacing the CPU**

*While replacing the CPU, always turn off the ATX power supply or unplug the power supply's power cord from the grounded outlet first to ensure the safety of CPU.*

#### **Overclocking**

*This mainboard is designed to support overclocking. However, please make sure your components are able to tolerate such abnormal setting, while doing overclocking. Any attempt to operate beyond product specifications is not recommended. We do not guarantee the damages or risks caused by inadequate operation or beyond product specifications.*

### **Introduction to FM1 APU**

The surface of CPU. Remember to apply some thermal paste on it for better heat dispersion.



## CPU & Cooler Installation

When you are installing the CPU, **make sure the CPU has a cooler attached on the top to prevent overheating.** Meanwhile, do not forget to apply some thermal paste on CPU before installing the heat sink/cooler fan for better heat dispersion.

Follow the steps below to install the CPU & cooler correctly. Wrong installation will cause the damage of your CPU & mainboard.

1. Pull the lever sideways away from the socket. Make sure to raise the lever up to a 90-degree angle.
2. Look for the gold arrow of the CPU. The gold arrow should point as shown in the picture. The CPU can only fit in the correct orientation.

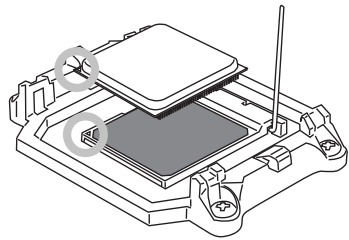
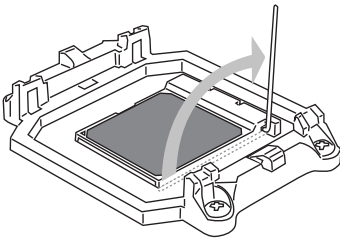

3. If the CPU is correctly installed, the pins should be completely embedded into the socket and can not be seen. Please note that any violation of the correct installation procedures may cause permanent damages to your mainboard.
4. Press the CPU down firmly into the socket and close the lever. As the CPU is likely to move while the lever is being closed, always close the lever with your fingers pressing tightly on top of the CPU to make sure the CPU is properly and completely embedded into the socket.

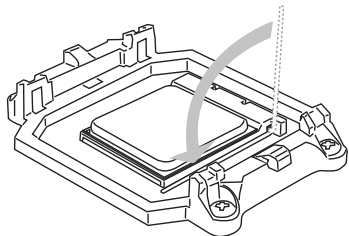
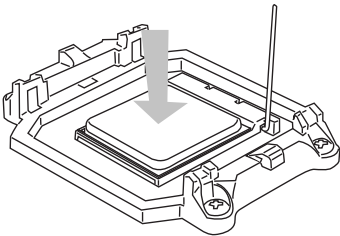

5. Position the cooling set onto the retention mechanism.  
Hook one end of the clip to hook first.

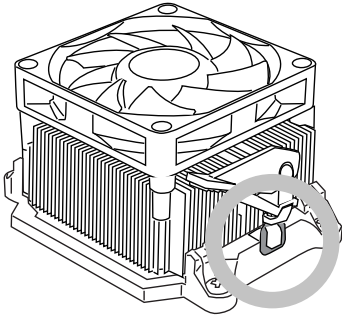

6. Then press down the other end of the clip to fasten the cooling set on the top of the retention mechanism.  
Locate the Fix Lever and lift up it .

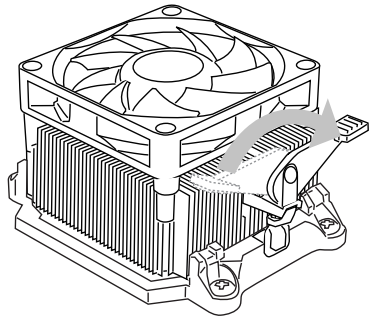

7. Fasten down the lever.

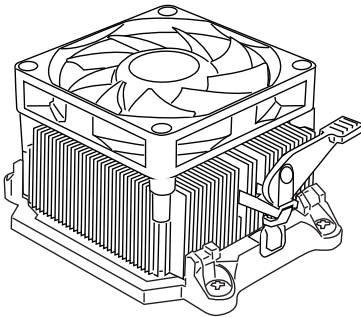

8. Attach the CPU Fan cable to the CPU fan connector on the mainboard.

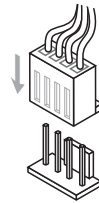

### **Important**

- While disconnecting the Safety Hook from the fixed bolt, it is necessary to keep an eye on your fingers, because once the Safety Hook is disconnected from the fixed bolt, the fixed lever will spring back instantly.

## Memory

These DIMM slots are used for installing memory modules. For more information on compatible components, please visit <http://www.msi.com/service/test-report>

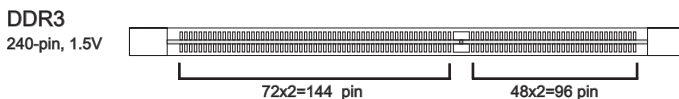

### Dual-Channel mode Population Rule

In Dual-Channel mode, the memory modules can transmit and receive data with two data bus lines simultaneously. Enabling Dual-Channel mode can enhance the system performance. The following illustrations explain the population rules for Dual-Channel mode.

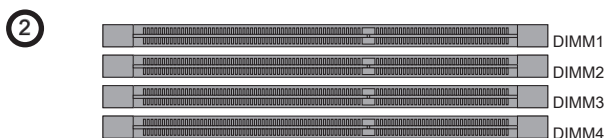
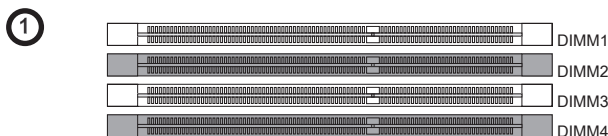

### Important

- DDR3 memory modules are not interchangeable with DDR2 and the DDR3 standard is not backwards compatible. You should always install DDR3 memory modules in the DDR3 DIMM slots.
- In Dual-Channel mode, make sure that you install memory modules of the **same type and density** in different channel DIMM slots.
- To enable successful system boot-up, always insert the memory modules into the DIMM4 first.
- Due to the chipset resource deployment, the system density will only be detected up to 31+GB (not full 32GB) when each DIMM is installed with a 8GB memory module.

## Installing Memory Modules

1. The memory module has only one notch on the center and will only fit in the right orientation.
2. Insert the memory module vertically into the DIMM slot. Then push it in until the golden finger on the memory module is deeply inserted in the DIMM slot. The plastic clip at each side of the DIMM slot will automatically close when the memory module is properly seated.
3. Manually check if the memory module has been locked in place by the DIMM slot clips at the sides.

### **Important**

*You can barely see the golden finger if the memory module is properly inserted in the DIMM slot.*

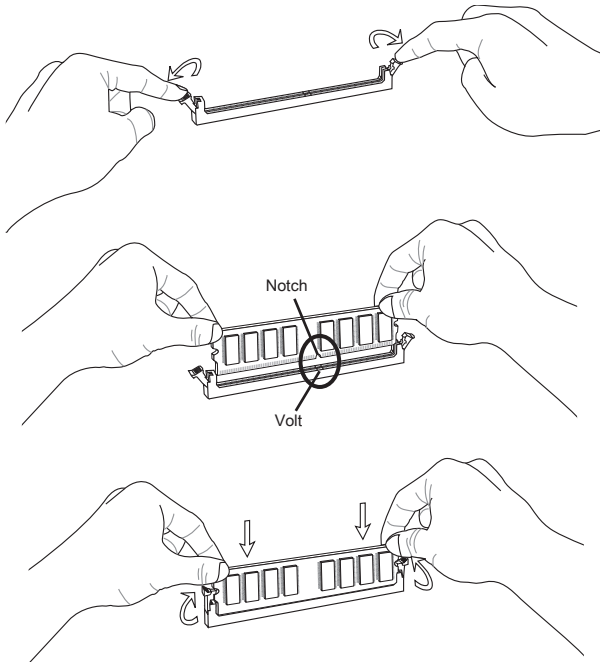



## Power Supply

### ATX 24-pin Power Connector: JPWR1

This connector allows you to connect an ATX 24-pin power supply. To connect the ATX 24-pin power supply, make sure the plug of the power supply is inserted in the proper orientation and the pins are aligned. Then push down the power supply firmly into the connector.

You may use the 20-pin ATX power supply as you like. If you'd like to use the 20-pin ATX power supply, please plug your power supply along with pin 1 & pin 13.

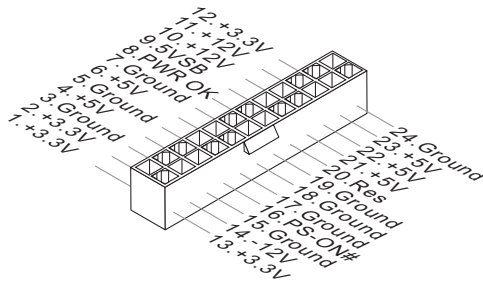

### ATX 4-pin Power Connector: JPWR2

This connector is used to provide the power output to the CPU.

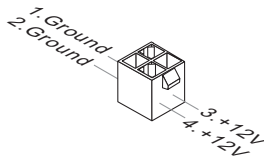

### **Important**

*Make sure that all the connectors are connected to proper ATX power supplies to ensure stable operation of the mainboard.*

## Back Panel

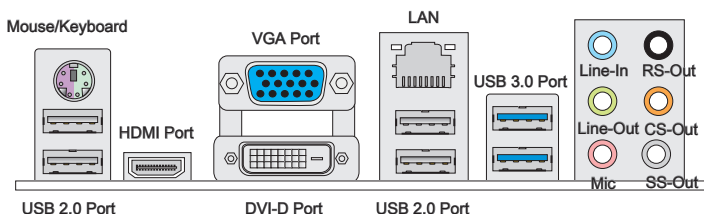

### ► Mouse/Keyboard

The standard PS/2® mouse/keyboard DIN connector is for a PS/2® mouse/keyboard.

### ► USB 2.0 Port

The USB 2.0 port is for attaching USB devices such as keyboard, mouse, or other USB-compatible devices. Supports data transfer rate up to 480Mbit/s (Hi-Speed).

### ► USB 3.0 Port

USB 3.0 port is backward-compatible with USB 2.0 devices. Supports data transfer rate up to 5 Gbit/s (SuperSpeed).

### **Important**

*If you want to use a USB 3.0 device, you must use the USB 3.0 cable to connect to the USB 3.0 port.*

### ► HDMI Port

The High-Definition Multimedia Interface (HDMI) is an all-digital audio/video interface capable of transmitting uncompressed streams. HDMI supports all TV format, including standard, enhanced, or high-definition video, plus multi-channel digital audio on a single cable.

### ► DVI-D Port

The DVI-D (Digital Visual Interface-Digital) connector allows you to connect a LCD monitor. It provides a high-speed digital interconnection between the computer and its display device. To connect an LCD monitor, simply plug your monitor cable into the DVI-D connector, and make sure that the other end of the cable is properly connected to your monitor (refer to your monitor manual for more information).

### **Important**

*This mainboard doesn't support HDMI-output & DVI-D-output simultaneously.*

### ▶ VGA Port

The DB15-pin female connector is provided for monitor.

### ▶ LAN

The standard RJ-45 LAN jack is for connection to the Local Area Network (LAN). You can connect a network cable to it.

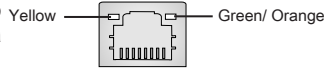

LED	Color	LED State	Condition
Left	Yellow	Off	LAN link is NOT established.
		On(Steady state)	LAN link is established.
		On(brighter & pulsing)	The computer is communicating with another computer on the LAN.
Right	Green	Off	10 Mbits/sec data rate is selected.
		On	100 Mbits/sec data rate is selected.
	Orange	On	1000 Mbits/sec data rate is selected.

### ▶ Audio Ports

These audio connectors are used for audio devices. It is easy to differentiate between audio effects according to the color of audio jacks.

- Line-In (Blue) - Line In, is used for external CD player, tape-player or other audio devices.
- Line-Out (Green) - Line Out, is a connector for speakers or headphones.
- Mic (Pink) - Mic, is a connector for microphones.
- RS-Out (Black) - Rear-Surround Out in 4/ 5.1/ 7.1 channel mode.
- CS-Out (Orange) - Center/ Subwoofer Out in 5.1/ 7.1 channel mode.
- SS-Out (Gray) - Side-Surround Out 7.1 channel mode.

## Connectors

### Serial ATA Connector: SATA1~6

This connector is a high-speed Serial ATA interface port. Each connector can connect to one Serial ATA device.

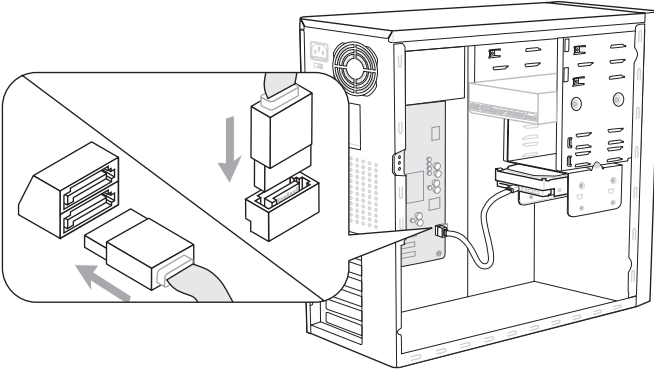

\* The MB layout in this figure is for reference only.

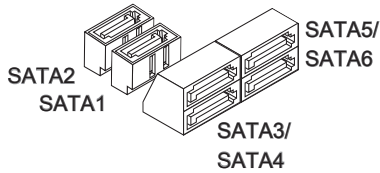

### **Important**

Please do not fold the Serial ATA cable into 90-degree angle. Otherwise, data loss may occur during transmission.

## Fan Power Connectors: CPUFAN, SYSFAN1, SYSFAN2

The fan power connectors support system cooling fan with +12V. When connecting the wire to the connectors, always note that the red wire is the positive and should be connected to the +12V; the black wire is Ground and should be connected to GND. If the mainboard has a System Hardware Monitor chipset on-board, you must use a specially designed fan with speed sensor to take advantage of the CPU fan control.

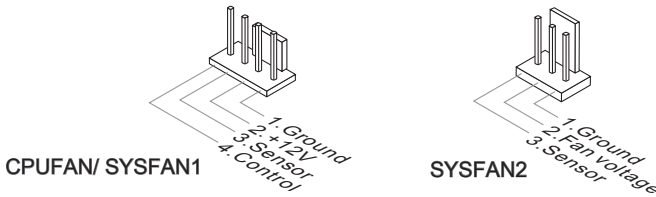

### Important

- Please refer to the recommended CPU fans at processor's official website or consult the vendors for proper CPU cooling fan.
- CPUFAN supports fan control. You can install **Control Center** utility that will automatically control the CPU fan speed according to the actual CPU temperature.
- Fan cooler set with 3 or 4 pins power connector are both available for CPUFAN.

## Chassis Intrusion Connector: JCI1

This connector connects to the chassis intrusion switch cable. If the chassis is opened, the chassis intrusion mechanism will be activated. The system will record this status and show a warning message on the screen. To clear the warning, you must enter the BIOS utility and clear the record.

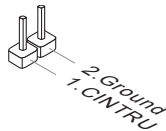

## Front Panel Connectors: JFP1, JFP2

These connectors are for electrical connection to the front panel switches and LEDs. The JFP1 is compliant with Intel® Front Panel I/O Connectivity Design Guide.

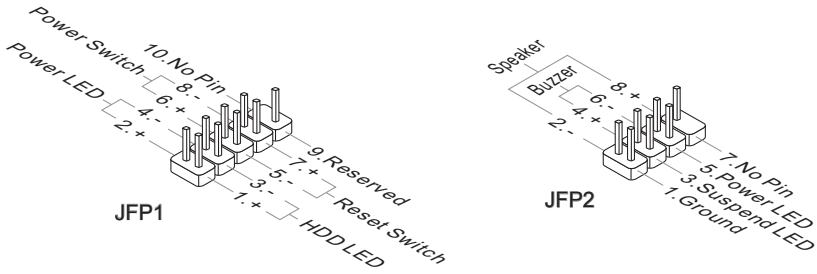

## Front USB 3.0 Connector: JUSB3

USB 3.0 port is backward-compatible with USB 2.0 devices. Supports data transfer rate up to 5 Gbit/s (SuperSpeed).

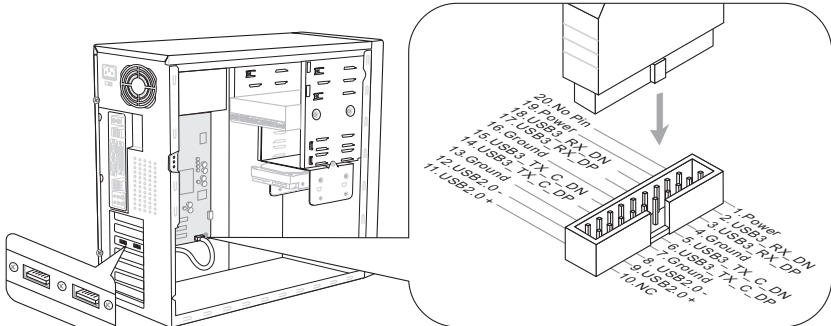

\* The MB layout in this figure is for reference only.

USB 3.0 Bracket (optional)

### **Important**

- Note that the pins of VCC and GND must be connected correctly to avoid possible damage.
- If you want to use a USB 3.0 device, you must use the USB 3.0 cable to connect to the USB 3.0 port.

## Front USB Connector: JUSB1 / JUSB2

This connector, compliant with Intel® I/O Connectivity Design Guide, is ideal for connecting high-speed USB interface peripherals such as USB HDD, digital cameras, MP3 players, printers, modems and the like.

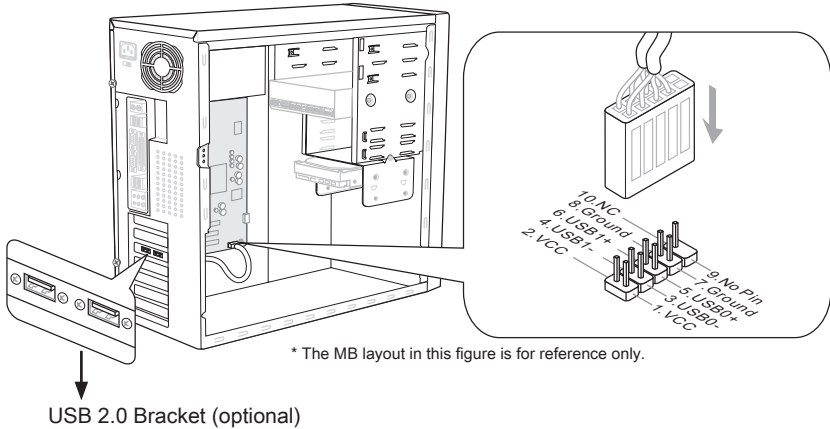

### **Important**

Note that the pins of VCC and GND must be connected correctly to avoid possible damage.

## Front Panel Audio Connector: JAUD1

This connector allows you to connect the front panel audio and is compliant with Intel® Front Panel I/O Connectivity Design Guide.

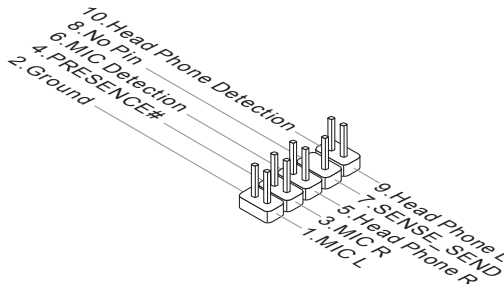

### TPM Module connector: JTPM1

This connector connects to a TPM (Trusted Platform Module) module (optional). Please refer to the TPM security platform manual for more details and usages.

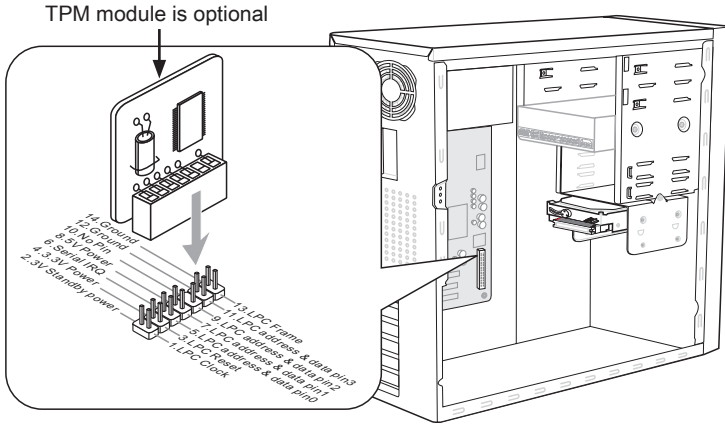

\* The MB layout in this figure is for reference only.

### S/PDIF-Out Connector: JSP1

This connector is used to connect S/PDIF (Sony & Philips Digital Interconnect Format) interface for digital audio transmission.

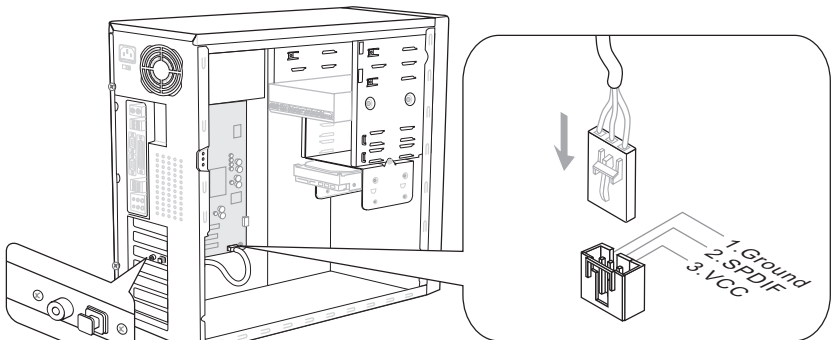

\* The MB layout in this figure is for reference only.

S/PDIF-Out Bracket (optional)



### Parallel Port Connector: JLPT1

This connector is used to connect an optional parallel port bracket. The parallel port is a standard printer port that supports Enhanced Parallel Port (EPP) and Extended Capabilities Parallel Port (ECP) mode.

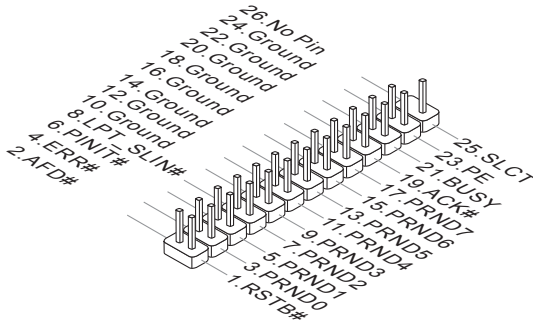

### Serial Port Connector: JCOM1

This connector is a 16550A high speed communication port that sends/receives 16 bytes FIFOs. You can attach a serial device.

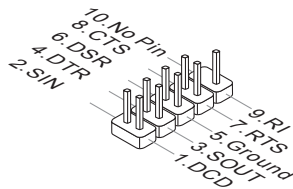

## Jumper

---

### Clear CMOS Jumper: JBAT1

There is a CMOS RAM onboard that has a power supply from an external battery to keep the data of system configuration. With the CMOS RAM, the system can automatically boot OS every time it is turned on. If you want to clear the system configuration, set the jumper to clear data.



JBAT1



Keep Data



Clear Data

### **Important**

*You can clear CMOS by shorting 2-3 pin while the system is off. Then return to 1-2 pin position. Avoid clearing the CMOS while the system is on; it will damage the main-board.*

## Slots

### PCIe Slot

The PCIe slot supports the PCIe interface expansion card.

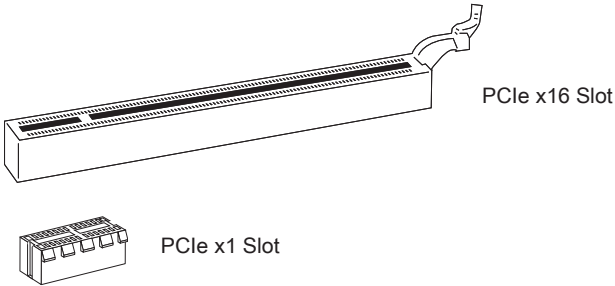

### PCI (Peripheral Component Interconnect) Slot

The PCI slot supports LAN card, SCSI card, USB card, and other add-on cards that comply with PCI specifications.

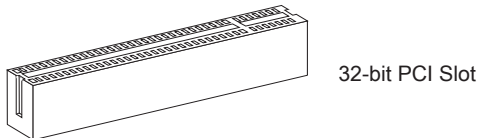

### **Important**

*When adding or removing expansion cards, make sure that you unplug the power supply first. Meanwhile, read the documentation for the expansion card to configure any necessary hardware or software settings for the expansion card, such as jumpers, switches or BIOS configuration.*

### PCI Interrupt Request Routing

The IRQ, acronym of interrupt request line and pronounced I-R-Q, are hardware lines over which devices can send interrupt signals to the microprocessor. The PCI IRQ pins are typically connected to the PCI bus pins as follows:

	Order1	Order2	Order3	Order4
PCI Slot1	INT E#	INT F#	INT G#	INT H#



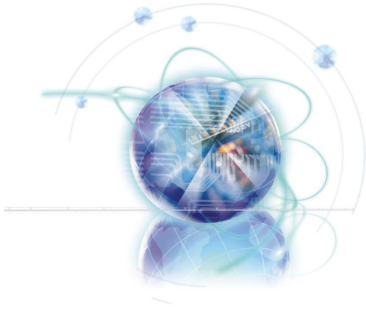

## Chapter 3

# BIOS Setup

This chapter provides information on the BIOS Setup program and allows you to configure the system for optimum use.

You may need to run the Setup program when:

- An error message appears on the screen during the system booting up, and requests you to run SETUP.
- You want to change the default settings for customized features.

## Entering Setup

---

Power on the computer and the system will start POST (Power On Self Test) process. When the message below appears on the screen, press <DEL> key to enter Setup.

### Press DEL to enter Setup Menu, F11 to enter Boot Menu

If the message disappears before you respond and you still wish to enter Setup, restart the system by turning it OFF and On or pressing the RESET button. You may also restart the system by simultaneously pressing <Ctrl>, <Alt>, and <Delete> keys.

### **Important**

- *The items under each BIOS category described in this chapter are under continuous update for better system performance. Therefore, the description may be slightly different from the latest BIOS and should be held for reference only.*
- *Upon boot-up, the 1st line appearing after the memory count is the BIOS version. It is usually in the format:*

*E7696AMS Vx.xxx 060511 where:*

*1st digit refers to BIOS type as E = EFI*

*2nd - 5th digit refers to the model number.*



*6th digit refers to the chipset as I = Intel, N = nVidia, A = AMD and V = VIA.*

*7th - 8th digit refers to the customer as MS = all standard customers.*

*Vx.xxx refers to the BIOS version.*

*060511 refers to the date this BIOS was released.*

## Control

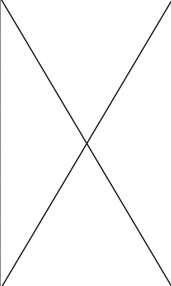
Keyboard	Mouse	Description
<↑><↓>		Select Item
<←><→>	Move the cursor	Select Screen
<Enter>	 Click/ Double-click the left button	Select Icon/ Field
<Esc>	 Click the right button	Jumps to the Exit menu or returns to the previous from a submenu
<+>		Increase the numeric value or make changes
<->		Decrease the numeric value or make changes
<F1>		General Help
<F4>		CPU Specifications
<F5>		Enter MEMORY-Z
<F6>		Load optimized defaults
<F10>		Save Change and Reset
<Esc>		Exit

### Sub-Menu

If you find a right pointer symbol (as shown in the right view) appears to the left of certain fields that means a sub-menu can be launched from this field. A sub-menu contains additional options for a field parameter. You can use arrow keys ( ↑ ↓ ) or mouse to highlight the field and press <Enter> or double-click the left mouse button to enter the sub-menu. Then you can use the control keys to enter values and move from field to field within a sub-menu. If you want to return to the previous menu, just press the <Esc > or click the right mouse button.

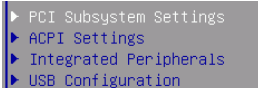

- ▶ PCI Subsystem Settings
- ▶ ACPI Settings
- ▶ Integrated Peripherals
- ▶ USB Configuration

### General Help <F1>

The BIOS setup program provides a General Help screen. You can call up this screen from any menu by simply pressing <F1>. The Help screen lists the appropriate keys to use and the possible selections for the highlighted item. Press <Esc> to exit the Help screen.

## The Menu Bar

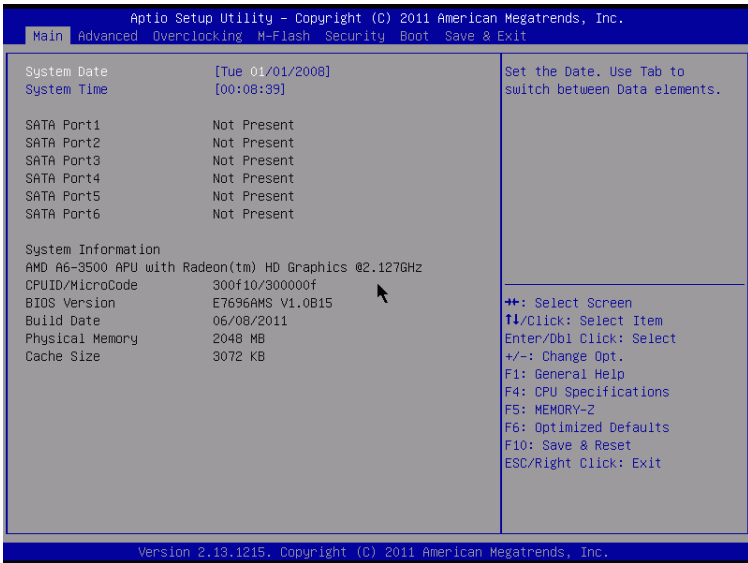

► **Main Menu**

Use this menu for basic system configurations, such as time, date etc.

► **Advanced**

Use this menu to setup the items of the BIOS special enhanced features, integrated peripherals, power management and PC health status.

► **Overclocking**

Use this menu to specify your settings for frequency/voltage control and overclocking.

► **M-Flash**

Use this menu to read/ flash the BIOS from storage drive (FAT/ FAT32 format only).

► **Security**

Use this menu to set supervisor and user passwords.

► **Boot**

Use this menu to specify the priority of boot devices.

► **Save & Exit**

This menu allows you to load the BIOS default values or factory default settings into the BIOS and exit the BIOS setup utility with or without changes.



## Main Menu

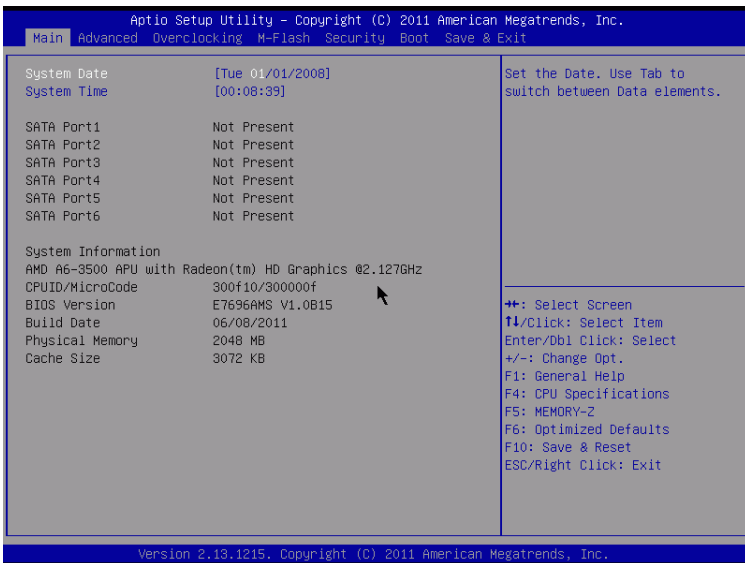

### ► System Date

This allows you to set the system to the date that you want (usually the current date). The format is <day><month> <date> <year>.

[day]	Day of the week, from Sun to Sat, determined by BIOS. Read-only.
[month]	The month from Jan. through Dec.
[date]	The date from 1 to 31 can be keyed by numeric function keys.
[year]	The year can be adjusted by users.

### ► System Time

This allows you to set the system time that you want (usually the current time). The time format is <hour> <minute> <second>.

### ► SATA Port1~6

Press <Enter> to enter the sub-menu. The sub-menu shows the information of installed SATA device.

### **Important**

*SATA Port1~6 are appearing when you connect the storage devices to the SATA connectors on the mainboard.*

### ► System Information

This area shows the CPU information, BIOS version and memory status of your system (read only).

# Advanced

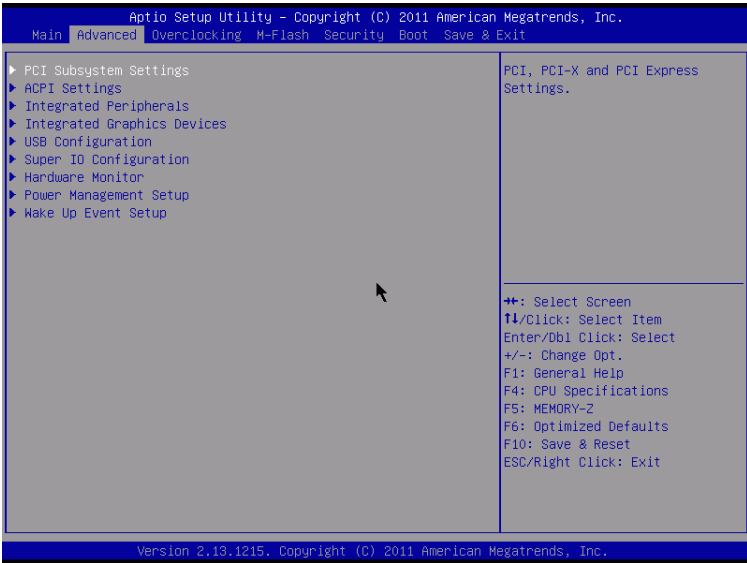

### ► PCI Subsystem Settings

Press <Enter> to enter the sub-menu.

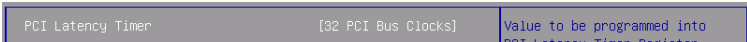

### ► PCI Latency Timer

This item controls how long each PCI device can hold the bus before another takes over. When set to higher values, every PCI device can conduct transactions for a longer time and thus improve the effective PCI bandwidth. For better PCI performance, you should set the item to higher values.

### ► ACPI Settings

Press <Enter> to enter the sub-menu.

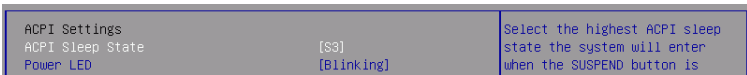

### ► ACPI Sleep State

This item specifies the power saving modes for ACPI function.

### ► Power LED

This item configures how the system uses power LED on the case to indicate the sleep/suspend state.

### ► Integrated Peripherals

Press <Enter> to enter the sub-menu.

Onboard Lan Configuration		Enable or Disable Onboard LAN Controller1.
Onboard LAN Controller1	[Enabled]	
LAN Option ROM	[Disabled]	
SATA Mode	[IDE Mode]	
HD Audio Controller	[Enabled]	
HPET	[Enabled]	

#### ► Onboard Lan Controller

This item allows you to enable/ disable the onboard LAN controller.

#### ► LAN Option ROM

This item is used to decide whether to invoke the Boot ROM of the onboard LAN.

#### ► SATA Mode

This item is used to specify a mode for SATA port.

#### ► HD Audio Controller

This item allows you to enable/ disable the HD audio controller.

#### ► HPET

The HPET (High Precision Event Timers) is a component that is part of the chipset. You can to enable it, and will provide you with the means to get to it via the various ACPI methods.

### ► Integrated Graphics Configuration

Press <Enter> to enter the sub-menu.

Integrated Graphics Devices Configuration		Select Primary Video Device that BIOS will use to for output.
Initiate Graphic Adapter	[IGD]	
Integrated Graphics	[Auto]	

#### ► Initiate Graphic Adapter

This setting specifies which graphic card is the initial graphics adapter.

#### ► Integrated Graphics

The system shares memory to the onboard graphics. This setting controls the exact memory size shared to the onboard graphics.

### ► USB Configuration

Press <Enter> to enter the sub-menu.

USB Configuration		USB Support Parameters
USB Devices:		
1 Drive, 1 Keyboard, 1 Hub		
USB Controller	[Enabled]	
Legacy USB Support	[Enabled]	
Onboard USB 3.0 Controller	[Enabled]	

#### ► USB Devices:

This item shows the type of installed USB device.

► **USB Controller**

This item allows you to enable/ disable the USB controller.

► **Legacy USB Support**

Set to [Enabled] if you need to use any USB 1.1/2.0 device in the operating system that does not support or have any USB 1.1/2.0 driver installed, such as DOS and SCO Unix. Set to [Disabled] only if you want to use any USB device other than the USB mouse.

► **Onboard USB 3.0 Controller**

This item allows you to enable/ disable the onboard USB 3.0 controller.

► **Super IO Configuration**

Press <Enter> to enter the sub-menu.



► **Serial(COM) Port 0 Configuration**

Press <Enter> to enter the sub-menu.

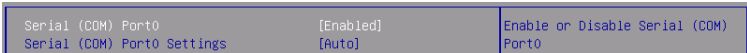

► **Serial (COM) Port0**

This item allows you to enable/ disable the serial port.

► **Serial (COM) Port0 Settings**

Select an address and corresponding interrupt for the serial port.

► **Parallel(LPT) Port Configuration**

Press <Enter> to enter the sub-menu.

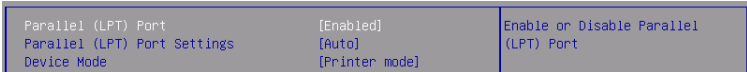

► **Parallel (LPT) Port**

This item allows you to enable/ disable the parallel port.

► **Parallel (LPT) Port Settings**

Select an address and corresponding interrupt for the parallel port.

► **Device Mode**

Select a device mode for parallel port.

► **Hardware Monitor**

Press <Enter> to enter the sub-menu.

CPU Smart Fan Target	[Disabled]	Set CPU Target Temperature
SYS Fan1 Control	[100%]	
SYS Fan2 Control	[100%]	
-----PC Health Status-----		
CPU Temperature	: +57 °C	
System Temperature	: +34 °C	
CPU FAN Speed	: 3131 RPM	
SYS FAN1 Speed	: 0 RPM	
SYS Fan2 Speed	: 0 RPM	

#### ► CPU Smart Fan Target

The Smart Fan function controls the CPU fan speed automatically depending on the current temperature to keep it with in a specific range. You can enable a fan target value here. If the current CPU fan temperature reaches to the target value, the smart fan function will be activated.

#### ► SYS Fan 1/ 2 Control

These items allow user to select how percentage of speed for the SYSFAN1/ SYS-FAN2.

#### ► CPU/ System Temperature, CPU FAN/ SYS FAN 1~2 Speed

These items show the current status of all of the monitored hardware components such as CPU/ system temperatures and all fans' speeds.

#### ► Power Management Setup

Press <Enter> to enter the sub-menu.

EUP 2013	[Enabled]	EUP 2013
Restore after AC Power Loss	[Power off]	

#### ► EUP 2013

This item is designed for Energy Using Products Lot 6 2013 (EuP) aka Energy Related Products (ErP). To reduce Power Consumption when system off or standby mode.

Note: When "Enabled" EuP 2013 setting, system don't support RTC wake up event function.

#### ► Restore after AC Power Loss

This item specifies whether your system will reboot after a power failure or interrupt occurs. Settings are:

[Power off]	Always leaves the computer in the power off state.
[Power on]	Always leaves the computer in the power on state.
[Last State]	Restore the system to the status before power failure or interrupt occurred.

► **Wake Up Event Setup**

Press <Enter> to enter the sub-menu.

Setup Wake Up Configuration	
Wake Up Event By	[BIOS]
Resume By PCI or PCI-E Device	[Disabled]
Resume From S3 by USB Device	[Disabled]
Resume From S3/S4/S5 by PS/2 Mouse	[Disabled]
Resume From S3/S4/S5 by PS/2 keyboard	[Disabled]

► **Wake Up Event By**

Setting to [BIOS] activates the following fields, and use the following fields to set the wake up events. Setting to [OS], the wake up events will be defined by OS.

► **Resume By PCI or PCI-E Device**

When set to [Enabled], the feature allows your system to be awakened from the power saving modes through any event on PCI or PCIE device.

► **Resume From S3 by USB Device**

The item allows the activity of the USB device to wake up the system from S3 (Suspend to RAM) sleep state.

► **Resume From S3/S4/S5 by PS/2 Mouse/ Keyboard**

These items determine whether the system will be awakened from what power saving modes when input signal of the PS/2 mouse/ keyboard is detected.

## Overclocking

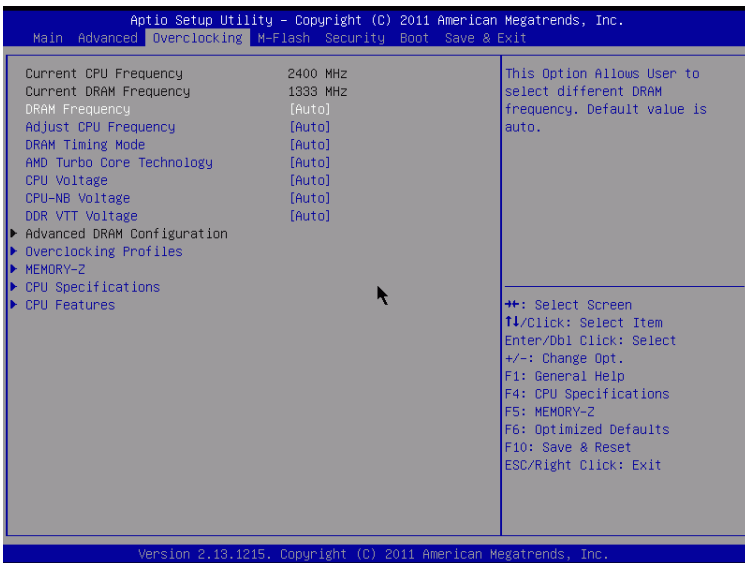

### ▶ Current CPU / DRAM Frequency

These items show the current clocks of CPU and Memory speed. Read-only.

### ▶ DRAM Frequency

This item is used to adjust the DRAM frequency. Setting to [Auto], the system will detect the DRAM Frequency automatically.

### ▶ Adjust CPU Frequency

This item is used to adjust the CPU frequency (in MHz).

### ▶ DRAM Timing Mode

This field has the capacity to automatically detect the DRAM timing.

### ▶ AMD Turbo Core Technology

This technology automatically increases the frequency of active CPU cores to improve performance.

### ▶ CPU Voltage/ CPU-NB Voltage/ DDR VTT Voltage

These items are used to adjust the voltage of CPU, CPU-NB and memory.

► **Advanced DRAM Configuration**

Press <Enter> to enter the sub-menu.

Command Rate	1	[Auto]	Command Rate is delay cycle between the memory controller start to send signal and the command can be sent to memory IC. Normally, you can select 1T to delay one cycle or 2T to delay two cycles. 1T will run faster but might be more unstable. Please set it depends on memory module.
tCL	5	[Auto]	
tRCD	5	[Auto]	
tRP	5	[Auto]	
tRAS	15	[Auto]	
tRC	16	[Auto]	
tWR	16	[Auto]	
tRRD	4	[Auto]	
tWTR	4	[Auto]	
tRFC0	0	[Auto]	
tRFC1	0	[Auto]	
► Advanced Channel Timing Configuration			
Bank Interleaving		[Auto]	

► **Command Rate**

This setting controls the DRAM command rate.

► **tCL**

This controls the CAS latency, which determines the timing delay (in clock cycles) before SDRAM starts a read command after receiving it.

► **tRCD**

When DRAM is refreshed, both rows and columns are addressed separately. This setup item allows you to determine the timing of the transition from RAS (row address strobe) to CAS (column address strobe). The less the clock cycles, the faster the DRAM performance.

► **tRP**

This setting controls the number of cycles for Row Address Strobe (RAS) to be allowed to precharge. If insufficient time is allowed for the RAS to accumulate its charge before DRAM refresh, refreshing may be incomplete and DRAM may fail to retain data. This item applies only when synchronous DRAM is installed in the system.

► **tRAS**

This setting determines the time RAS takes to read from and write to memory cell.

► **tRC**

The row cycle time determines the minimum number of clock cycles a memory row takes to complete a full cycle, from row activation up to the precharging of the active row.

► **tWR**

Minimum time interval between end of write data burst and the start of a precharge command. Allows sense amplifiers to restore data to cells.

► **tRRD**

Specifies the active-to-active delay of different banks.



### ▶ tWTR

Minimum time interval between the end of write data burst and the start of a column-read command. It allows I/O gating to overdrive sense amplifiers before read command starts.

### ▶ tRFC0/ 1

These settings determine the time RFC0/1 takes to read from and write to a memory cell.

### ▶ Advanced Channel 1/ 2 Timing Configuration

Press <Enter> to enter the sub-menu. And you can set the advanced memory timing for each channel.

tRWTT0	2	[Auto]	tRWTT0 is Read to Write
tWRRD	1	[Auto]	turnaround; specifies the
tWRWR	1	[Auto]	minimum number of clock cycles
tRDRD	2	[Auto]	from the last clock of virtual
			row to first read burst

### ▶ tRWTT0/ tWRRD/ tWRWR/ tRDRD

These items is used to set the memory timings for memory channel 1/ 2.

### ▶ Bank Interleaving

Bank Interleaving is an important parameter for improving overclocking capability of memory. It allows system to access multiple banks simultaneously.

### ▶ Overclocking profiles

Press <Enter> to enter the sub-menu.

▶ Overclocking Profile 1	Overclocking Profile 1
▶ Overclocking Profile 2	
▶ Overclocking Profile 3	
▶ Overclocking Profile 4	
▶ Overclocking Profile 5	
▶ Overclocking Profile 6	
OC Retry Count	[3]

### ▶ Overclocking Profile 1/ 2/ 3/ 4/ 5/ 6

Press <Enter> to enter the sub-menu. In the sub-menu, these items are used to save the current settings, and you can to load the settings from the stored profile.

### ▶ OC Retry Count

When overclocking has failed, setting this item as [1, 3] will allow system to reboot 1/ 3 times with the same overclocked configuration. If overclocking has failed every time, the system will restore the defaults.

### ▶ MEMORY-Z

Press <Enter> to enter the sub-menu.

▶ DIMM1 Memory SPD	Memory SPD Configuration
--------------------	--------------------------

### ▶ DIMM1~4 Memory SPD

Press <Enter> to enter the sub-menu. The sub-menu displays the informations of installed memory.

► CPU Specifications

Press <Enter> to enter the sub-menu. The submenu shows the information of installed CPU.

AMD A6-3500 APU with Radeon(tm) HD Graphics		CPU Technology Support
CPUID	300f10	
MicroCode	300000f	
CPU Frequency	2.117 GHz	
Cache L1	64KB	
Cache L2	3072KB	
Cache L3	0KB	
Core VID	1.750V	
Current Core VID	1.264V	
Core Number	3	
CPU Stepping	0	
► CPU Technology Support		

► CPU Technology Support

Press <Enter> to enter the sub-menu. The sub-menu shows the installed CPU technologies. Read only.

► CPU Features

Press <Enter> to enter the sub-menu.

AMD Cool'n'Quiet	[Enabled]	Enable/disable PowerNow function
SVM	[Enabled]	
IOMMU Mode	[Disabled]	
C6 Mode	[Disabled]	

► AMD Cool'n'Quiet

The Cool'n'Quiet technology can effectively and dynamically lower CPU speed and power consumption.

**Important**

To ensure that Cool'n'Quiet function is activated and will be working properly, it is required to double confirm that:

- Run BIOS Setup, and select Overclocking Menu. Under Overclocking Menu, find CPU Feature > AMD Cool'n'Quiet, and set this item to "Enabled".
- Enter Windows, and select [Start]->[Settings]->[Control Panel]->[Power Options]. Enter Power Options Properties tag, and select Minimal Power Management under Power schemes.

## M-Flash



### ► BIOS Boot Function

This allows you to enable/ disable the system to boot from the BIOS file inside USB drive (FAT/ 32 format only).

### ► Select one file to boot

When the BIOS Boot function as sets to [Enabled], this item is selectable. This item allows to select particular BIOS file from the USB/ Storage (FAT/ 32 format only) drive. And the system will boot from selected BIOS file.

### ► Save BIOS to storage

Please setup a specific folder in specific USB/ Storage drive to save BIOS file from BIOS ROM chip data. Note: it only supports FAT/ 32 file system drive.

### ► Select one file to update BIOS

This item allows you to select particular BIOS file from the USB/ Storage (FAT/ 32 format only) drive for updating BIOS.

# Security

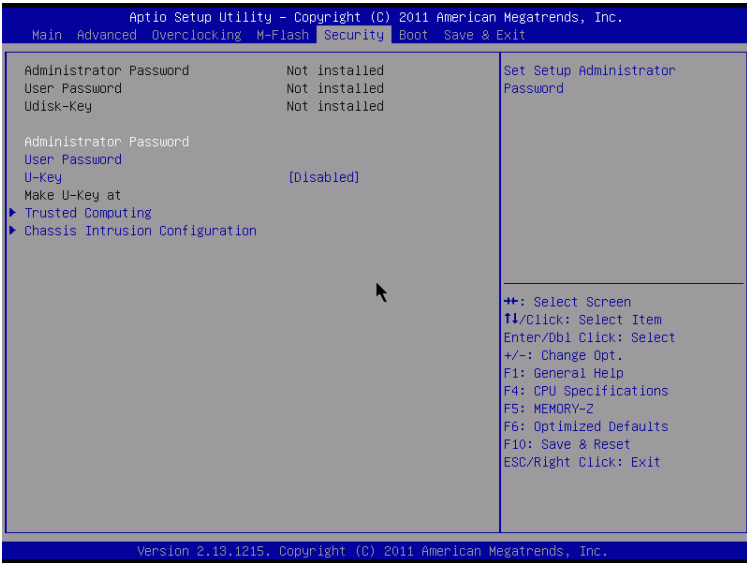

▶ **Administrator Password**

This item is used to set the administrator password. When a administrator password has been set, you will be prompted to enter it every time you try to enter BIOS Setup.

▶ **User Password**

This item is used to set the user password. When a user password has been set, you will be prompted to enter it every time you try to enter the operating system.

**Important**

When you select the Administrator Password / User Password item, a password box will appear on the screen. Type the password, and press <Enter>. The password typed now will replace any previously set password from CMOS memory. You will be prompted to confirm the password. Retype the password and press <Enter>. You may also press <Esc> to abort the selection and not enter a password.

To clear a set password, just press <Enter> when you are prompted to enter the password. A message will show up confirming the password will be disabled. Once the password is disabled, the system will boot and you can enter Setup/ OS without entering any password.

These two items prevent an unauthorized person from changing any part of your system configuration.

▶ **U-Key**

This item is used to enable/ disable USB drive as a key.

### ► Make U-Key at

When the “U-Key” as sets to [Enabled], this item is selectable. This item allows you to specify the USB drive.

### ► Trusted Computing

Press <Enter> to enter the sub-menu.

Configuration TPM SUPPORT [Disable]	Enables or Disables BIOS support for security device. O.S. will not show Security Device, TCG EFI protocol and INT1A interface will not be available.
Current Status Information NO Security Device Found	

### ► TPM SUPPORT

Setting the option to [Enabled] enables TPM (Trusted Platform Module) to the system.

### ► Chassis Intrusion Configuration

Press <Enter> to enter the sub-menu.

Chassis Intrusion Configuration Chassis Intrusion [Disabled]	Chassis Intrusion function
---	----------------------------

### ► Chassis Intrusion

This item enables or disables the feature of recording the chassis intrusion status and issuing a warning message if the chassis is once opened. To clear the warning message, set the field to [Reset]. The setting of the field will automatically return to [Enabled] later.

# Boot

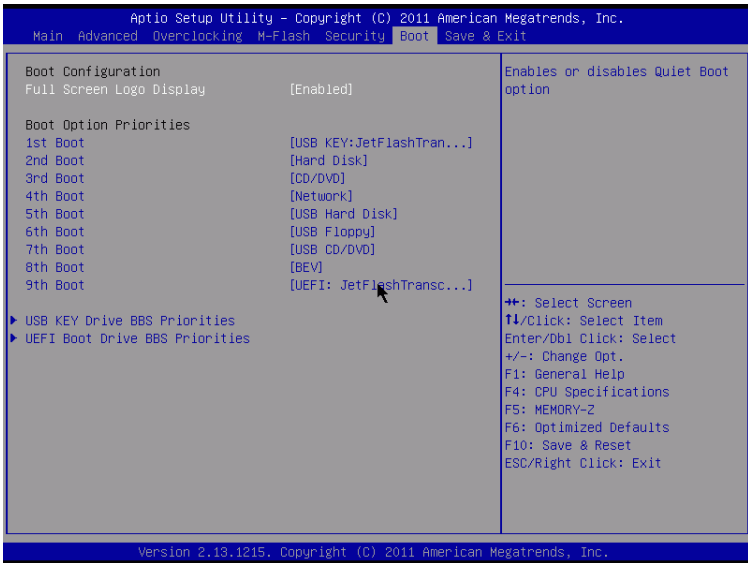

### ► Full Screen Logo Display

This item enables this system to show the company logo on the boot-up screen. Settings are:

- [Enabled]      Shows a still image (logo) on the full screen at boot.
- [Disabled]     Shows the POST messages at boot.

== Boot Option Priorities ==

### ► 1st~9th Boot

You can select the boot priorities in these Boot Option items.

### ► USB KEY Drive/ UEFI Boot Drive BBS Priorities

#### ► Boot Option

You can select the USB KEY Drive/ UEFI Boot priorities in these Boot Option items.

## Save & Exit

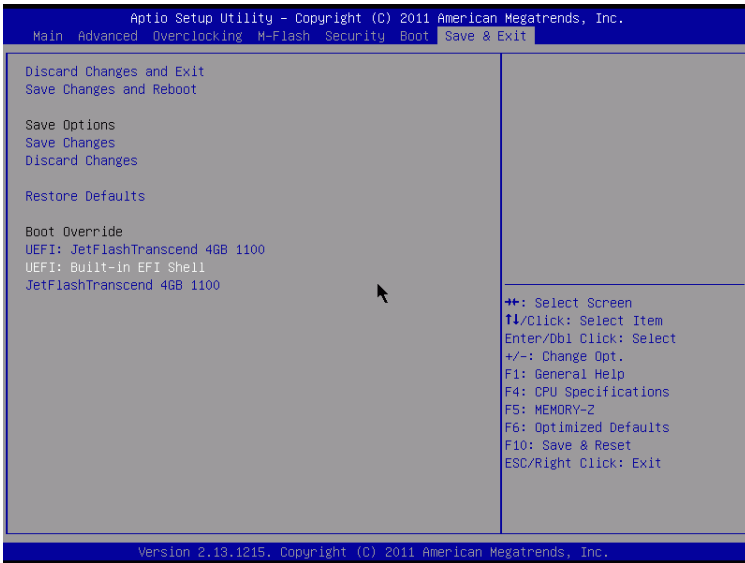

### ► Discard Changes and Exit

Use this item to abandon all changes and exit setup.

### ► Save Changes and Reboot

Use this item to save changes and reset the system.

### ► Save Changes

Use this item to save changes.

### ► Discard Changes

Use this item to abandon all changes.

### ► Restore Defaults

Use this item to load the optimized default values set by the BIOS vendor.

### == Boot Override ==

The installed storage devices will appear on this menu, you can select one of them be a boot device.

### ► Built-in EFI Shell

Use this item to enter the EFI Shell.





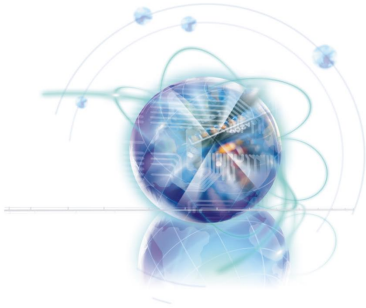

## *Appendix A*

# *Realtek Audio*

The Realtek audio provides 10-channel DAC that simultaneously supports 7.1 sound playback and 2 channels of independent stereo sound output (multiple streaming) through the Front-Out-Left and Front-Out-Right channels.

## Installing the Realtek HD Audio Driver

You need to install the HD audio driver for Realtek audio codec to function properly before you can get access to 2-, 4-, 6-, 8- channel or 7.1+2 channel audio operations. Follow the procedures described below to install the drivers for different operating systems.

### Installation for Windows®

For Windows® XP, you must install Windows® XP Service Pack3 or later before installing the driver.

The following illustrations are based on Windows®7 environment and could look slightly different if you install the drivers in different operating systems.

1. Insert the application DVD into the DVD-ROM drive. The setup screen will automatically appear.
2. Click Driver tab.
3. Click AUDIO button.



4. Select Realtek HD Audio Drivers to start installing the drivers.
5. Click Next to install the Realtek High Definition Audio Driver.
6. Follow the on-screen instructions to install drivers.
7. Click Finish to restart the system.

### **Important**

*The HD Audio Configuration software utility is under continuous update to enhance audio applications. Hence, the program screens shown here in this section may be slightly different from the latest software utility and shall be held for reference only.*

## Software Configuration

After installing the audio driver, the “Realtek HD Audio Manager” icon will appear at the notification area (lower right of the screen). You may double click the icon and the GUI will pop up accordingly.

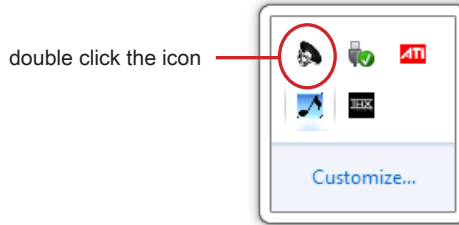

It is also available to enable the audio driver by clicking the Realtek HD Audio Manager from the Control Panel.

## Software panel overview

The following figure describes the function of the Realtek HD Audio Manager panel.

Device Selection

Application Enhancement

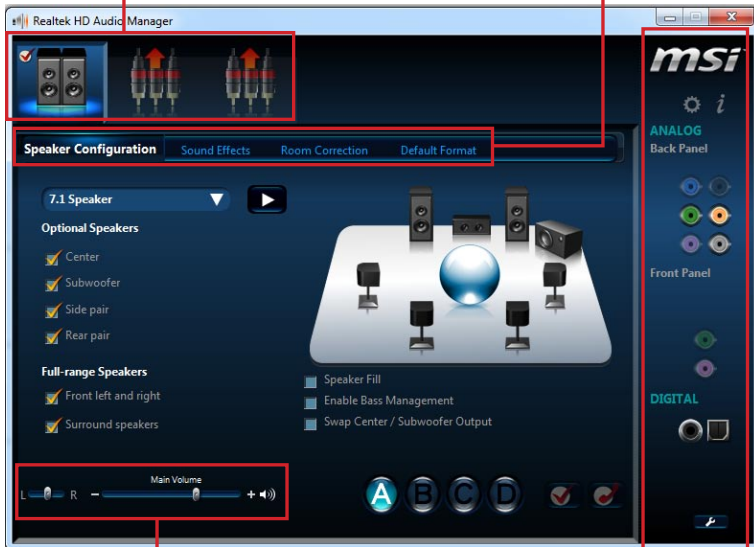

Volume Adjustment

Jack status panel

■ **Device Selection**

Here you can select a audio output source to change the related options. The “check” sign (in orange) indicates the devices as default.

■ **Volume Adjustment**

You can control the volume or balance the right/left side of the speakers that you plugged in front or rear panel by adjust the bar.

■ **Application Enhancement**

The array of options will provide you a complete guidance of anticipated sound effect for both output and input device.

■ **Jack status panel**

This panel depicts all render and capture devices currently connected with your computer.

### Auto popup dialog

When you plug into the device at the jack, a dialogue window will pop up asking you which device is current connected.

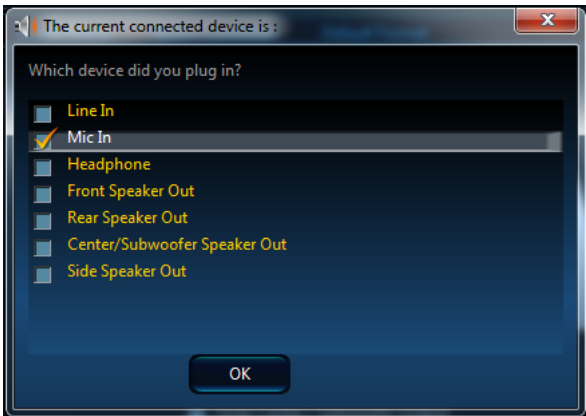

As you know, each jack corresponds to its default setting, you can refer to the next section “Hardware Default Setting”.

## Hardware Default Setting

The following diagrams are audio back panel default setting.

- Backpanel audio jacks to 2-channel speakers diagram

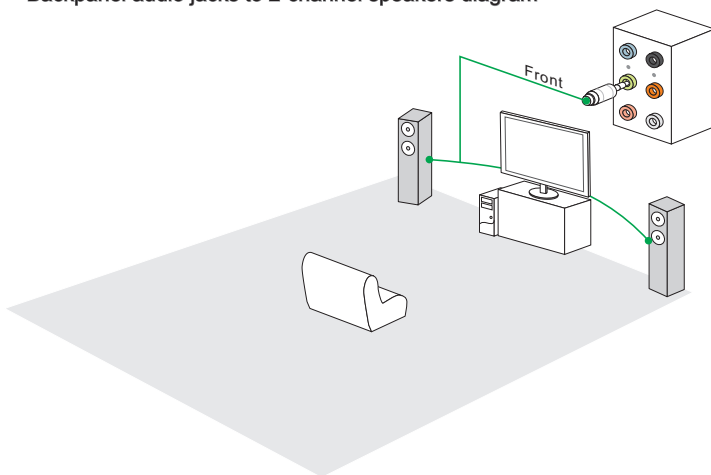

- Backpanel audio jacks to 4-channel speakers diagram

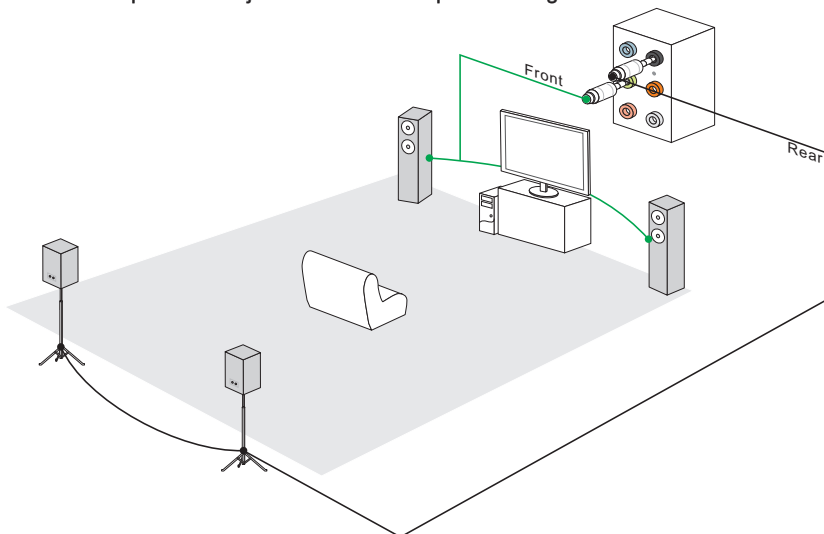

■ Backpanel audio jacks to 6-channel speakers diagram

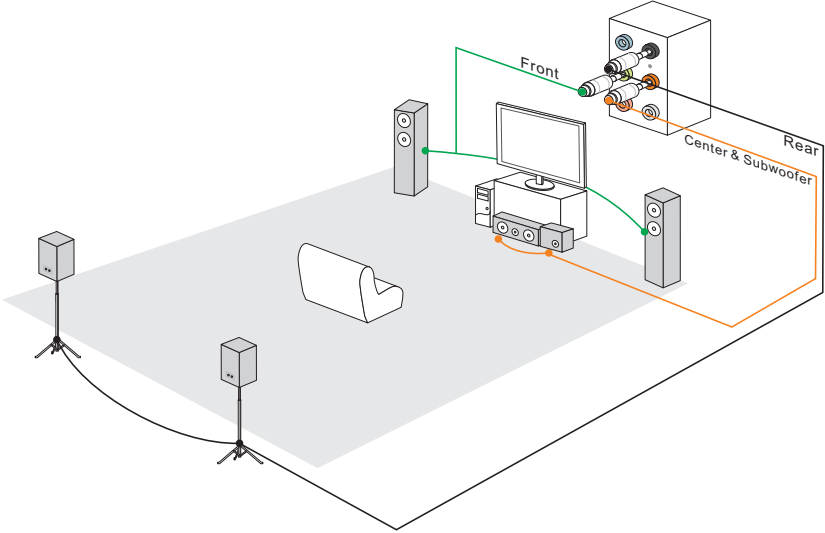

■ Backpanel audio jacks to 8-channel speakers diagram

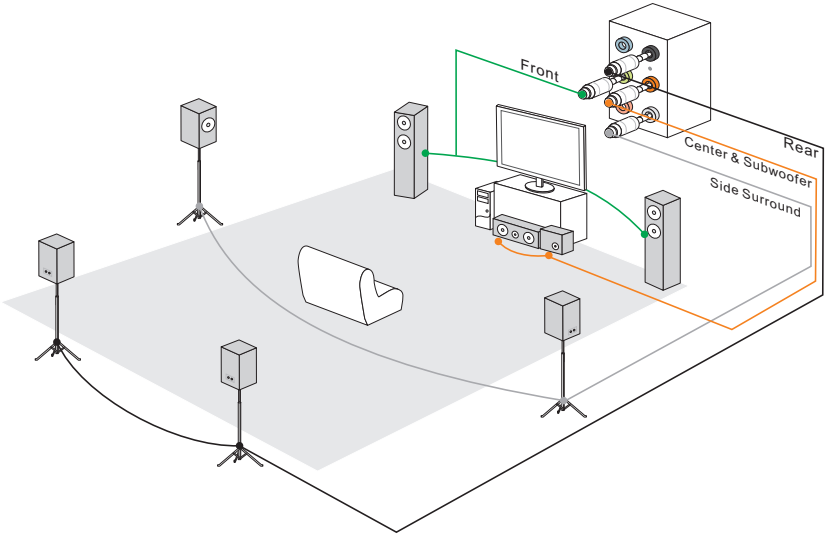

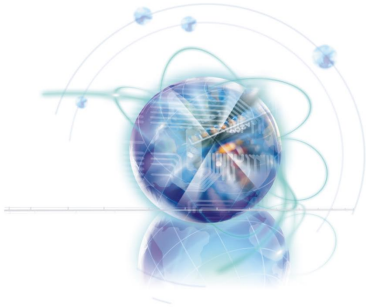

## ***Appendix B***

# ***AMD RAID***

The integrate one SATA host controller separately, and support RAID function for performance and reliability.

The SATA RAID provides support for RAID 0 (Striping), RAID 1 (Mirroring) & RAID 10 (Striping & Mirroring) . RAID 0 greatly improves hard disk I/O performance by concurrently striping data across multiple drives. RAID 1 makes sure data is not lost if a drive fails as data is simultaneously written to two drives. Drives configured for RAID Striping are said to form a RAID 0 set, while drives configured for RAID Mirroring are said to form a RAID 1 set. RAID 10 is implemented as a mirrored array whose segments are RAID 0 arrays. RAID 10 has same fault tolerance as mirroring and reduces overhead by striping. It needs at least four drives to form a RAID 10.

## RAID Configuration

Creating and deleting RAID set and performing other RAID setting up operations are done in the RAID BIOS. During bootup, a screen similar to the one below will appear for about few seconds. Press <Ctrl-F> to enter RAID Option ROM utility.

Press <Ctrl-F> to enter RAID Option ROM utility...

### **Important**

*Be sure to enable the RAID function for SATA device in BIOS before configuring the RAID Option ROM Utility.*

The RAID Option ROM utility menu screen will appear. The Main Menu is used to choose the operation to be performed.





## View Drives Assignments

This window displays the model number, capacities and assignment of the drives physically attached to the SATA host adapter.

[ View Drives Assignments ]				
Port : ID	Drive Model	Capabilities	Capacity (GB)	Assignment
01 : 00	ST32000641AS	SATA 6G	2000.39	<Single Disk>
	Extent 1		2000.39	<Single Disk>
02 : 00	ST32000641AS	SATA 6G	2000.39	<Single Disk>
	Extent 1		2000.39	<Single Disk>

  

[ Keys Available ]				
[ ↑ ] Up	[ ↓ ] Down	[ PaUp / PaDn ] Switch Page	[ Ctrl + H ] Full Erase	
[ ESC ] Exit				

**LD View / LD Define Menu (Creating RAID)**

The selection of the RAID configuration should be based upon factors including performance, data security, and the number of drives available. It is best to carefully consider the long-term role of the system and plan the data storage strategy. RAID sets can be created either automatically, or to allow the greatest flexibility, manually.

1. Press 2 on the Main Menu screen to enter the LD View Menu.

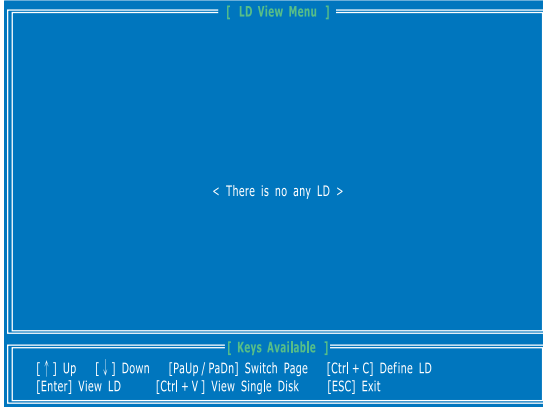

2. And then press [Ctrl + C] keys to enter the LD Define Menu. Use the space key to choose a RAID mode (RAID 0/ 1/ 10) and use the arrow key to move to the "Drives Assignments" window.

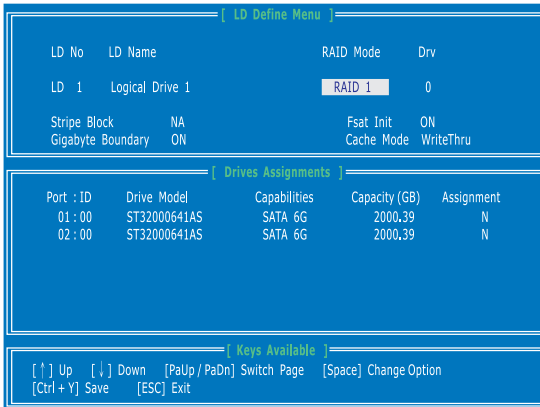

- Stripe Block Size, the default 64KB is best for most applications. RAID 0 or 10 only.
  - Gigabyte Boundary, allows use of slightly smaller replacement drives.
3. On the Drives Assignments window, use the arrow key to choose the hard drives which you want to make part of the LD, use the space key to change the assignment to "Y". Then press [Ctrl+Y] to save the configuration.

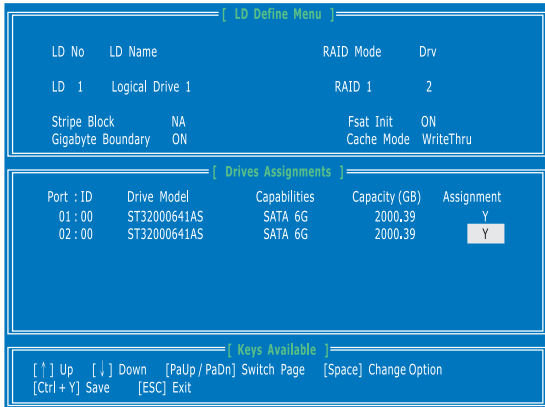

4. A message will show, press [Ctrl + Y] to input a LD name as your desire or press any key to save default LD name.

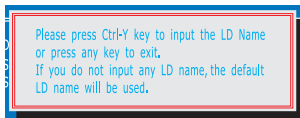

5. Another message will show, press [Ctrl-Y] if you are sure to erase the MBR data of the disk. Or press any key to ignore this option.

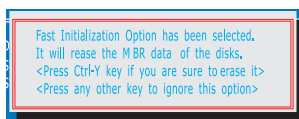

- 6. The message will show up on the bottom, press any key to use maximum capacity or press [Ctrl-Y] to modify array capacity manually.

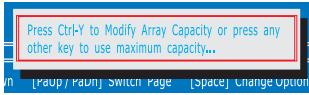

**Important**

- The default capacity is the full capacity of the selected hard drives.
- If you allocate the first LD capacity manually, you can create second LD with remaining capacity of the selected hard drives.

- 7. The LD creation is done, the screen shows the LD information as below. Press ESC key to the main screen.

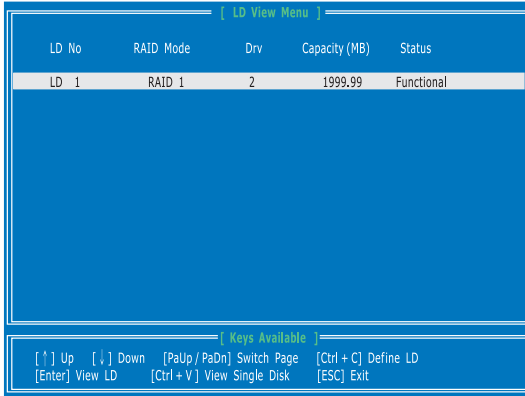

- 8. Press ESC key to exit the utility, a message "System is going to REBOOT! Are You Sure?" will display, answer "Y" to exit it and the system will reboot.

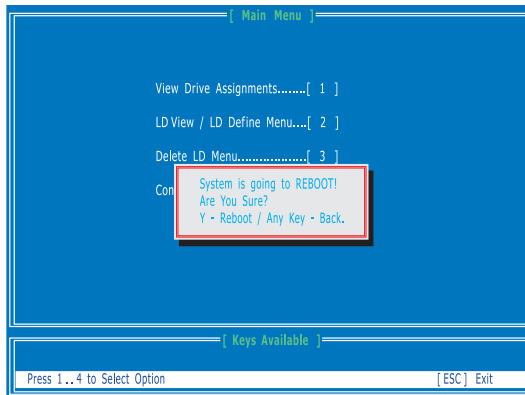

### Delete LD Menu (Deleting RAID)

1. Press "3" on the main to enter the Delete LD Menu.
2. Choose a LD No. you want to delete and press [Del] or [Alt+D] delete the RAID set.

[ Delete LD Menu ]					
LD No	RAID Mode	Drv	Capacity (MB)	Status	
LD 1	RAID 1	2	1999.99	Functional	

[ Keys Available ]					
[↑] Up	[↓] Down	[PaUp / PaDn]	Switch Page	[Del / Alt+D]	Delete LD

3. On the next screen, a message will display to inform you, press "Ctrl+Y" to delete the RAID set or other key to abort it. Press "Ctrl+Y" to complete the deletion.

[ View LD Definition Menu ]					
LD No	LD Name	RAID Mode	Drv	Capacity (GB)	
LD 1	Logical Drive 1	RAID 1	0	1999.99	
Stripe Block	NA	Cache Mode	WriteThru		

[ Drives Assignments ]					
Port : ID	Drive Model	Capabilities	Capacity (GB)	Assignment	
01 : 00	ST32000641AS	SATA 6G	2000.39	N	
02 : 00	ST32000641AS	SATA 6G	2000.39	N	

Press Ctrl-Y to delete the data in the disk! Or press any other key to abort...					
--	--	--	--	--	--

## Installing the RAID Driver (for bootable RAID Array)

1. After you complete the RAID BIOS setup, boot from the Windows CD, and the Windows Setup program starts.
2. Press F6 and wait for the Windows Setup screen to appear.
3. Insert the floppy that contains the RAID driver, press the "S" key to select "Specify Additional Device".  
**Note:** for Windows Vista/ Windows 7, you can copy the files to a medium (floppy/ CD/ DVD or USB)

### **Important**

*Please follow the instruction below to make a SATA RAID driver for yourself.*

- *Insert the MSI DVD into the DVD-ROM drive.*
  - *Click the "Browse CD" on the Setup screen.*
  - *Copy all the contents in the : \\ChipSet\AMD\Packages\Drivers\SBDrv\SB8xx\RAID\ (and then, please select a folder which was classified according to OS.)*
  - *The driver disk for RAID controller is done.*
4. When prompted, insert the medium disk and press Enter.  
For Windows Vista/ Windows 7:  
During the Operating system installation, after selecting the location to install Vista/ Windows 7 click on "Load Driver" button to load RAID drive.
  5. You should be shown a list of available RAID controller(s).
  6. Select the compatible RAID controller for 32-bit/ 64-bit version system and then press ENTER.
  7. The next screen should confirm that you have selected the RAID controller. Press ENTER again to continue.
  8. You have successfully installed the RAID driver, and Windows setup should continue.
  9. Leave the medium until the system reboots itself. Windows setup will need to copy the files from the medium again after the RAID volume is formatted, and Windows setup starts copying files.

## Installing the RAID Driver Under Windows (for Non-bootable RAID Array)

1. Insert the MSI DVD into the DVD-ROM drive.
2. The DVD will auto-run and the setup screen will appear.
3. Under the Driver tab, click on AMD chipset drivers by your need. The AMD chipset drivers includes RAID Driver.
4. The driver will be automatically installed.

